

Maule Aircraft Corporation

SPENCE AIR BASE :: MOULTREE, GEORGIA 31768 :: PHONE 912/985-2045

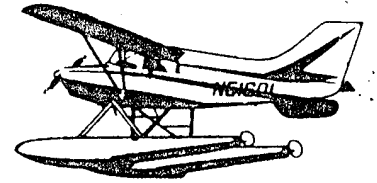

4 March 1977

SERVICE LETTER #38

SUBJECT: Possible float plane reinforcement deficiency.

MODELS AFFECTED: M-5-235C, S/N 7073C thru 7077C, 7079C, and 7085C.

COMPLIANCE: Immediate, if aircraft has floats installed, within 50 flight hours otherwise.

AUTHORITY: This Service Letter is FAA Approved.

BACKGROUND: There is a possibility that tube #127 (Fuselage bottom, transverse, at the rear/cargo door junction) was not reinforced when the float plane reinforcement kit was installed on these airplanes.

CORRECTIVE ACTION:

Inspect the subject tube to determine its diameter. The tube in question is on the fuselage bottom, running crosswise, 72 inches aft of the firewall. If this tube is 7/8 inch in diameter, your airplane has the proper reinforcement. So indicate on the Service Letter Compliance Record and return it to us.

If the tube is 3/4 inch in diameter, the float plane reinforcement was not installed on this tube. If you now have the aircraft mounted on floats, you must install this reinforcement before you fly it again.

If the airplane is not installed on floats, and you do not intend to install it on floats, you have the option of installing the reinforcement, or not.

If you do not install the reinforcement, make the following entry in your aircraft log book:

"Service Letter #38 not complied with. Therefore, the float plane reinforcing kit for this airplane is not complete, and it should not be installed on floats until service letter #38 is complied with."

You should then fill out the Service Letter Compliance Record and return it to us.

If you do desire to complete the float plane reinforcing kit, follow the instructions below, complete the Service Letter Compliance Record, and return it to us. Maule Aircraft Corporation will supply the reinforcement tube at no charge if you will order the "Service Letter #38 Kit" from us.

SERVICE LETTER #38

REINFORCEMENT INSTALLATION INSTRUCTIONS

1. Slide reinforcing tube into fuselage belly below and behind tube to be reinforced, with the channel opening up and the slot forward.
2. Align the slot in the reinforcement with the fabric Stand-off tube and slide the reinforcement up around tube #127, still with the channel opening up.
3. Clamp the reinforcement to the tube and weld both sides of the channel, at the top, to the tube, using a $3/4$ inch fillet weld every three inches.

CAUTION: Spread wet cloths over the fabric in the area being welded, and have a fire extinguisher handy.

4. Weld slot closed.
5. Paint the reinforced tube with zinc chromate.

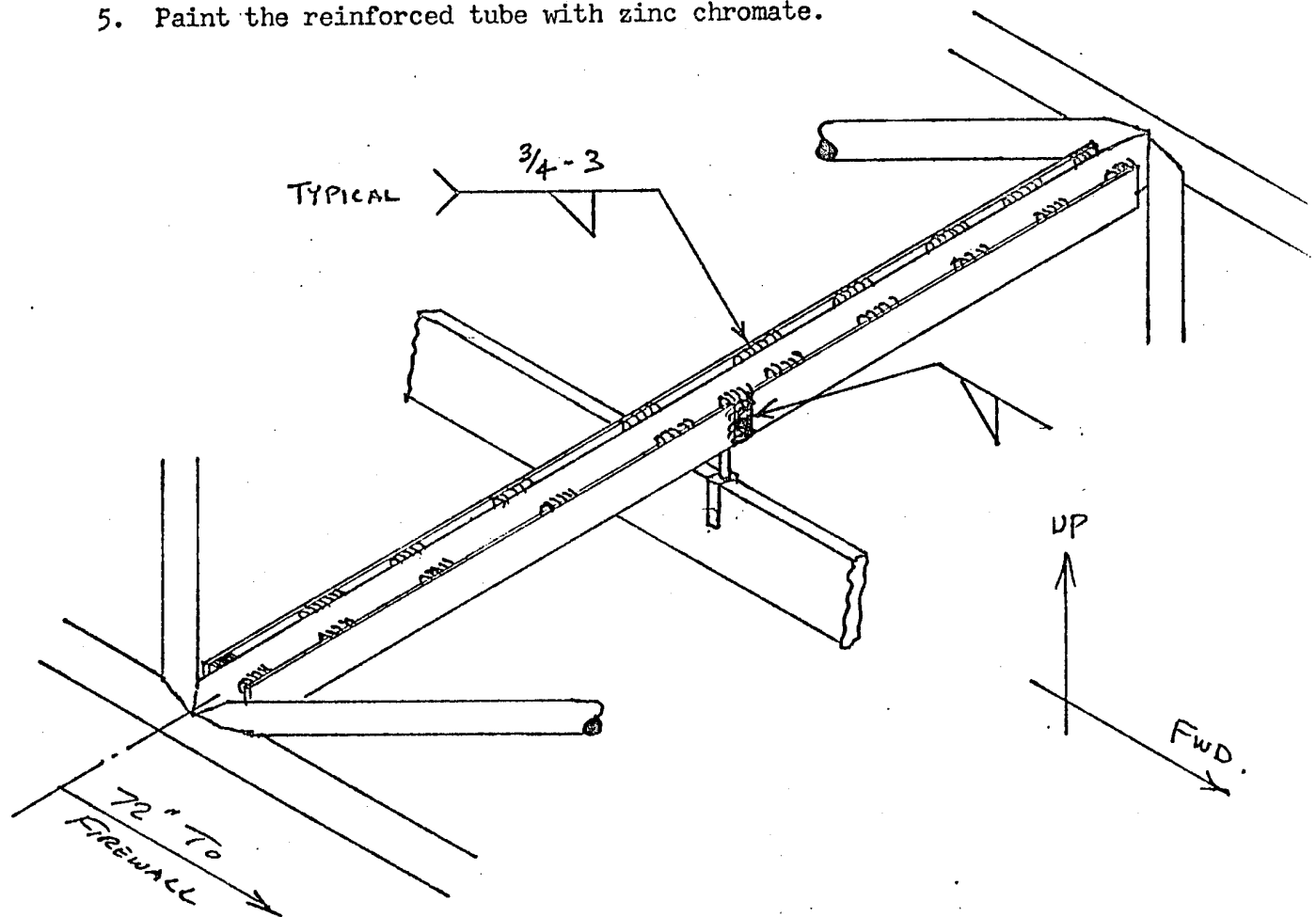

MAULE AIRCRAFT CORPORATION
SERVICE LETTER #38 COMPLIANCE RECORD

Aircraft Serial Number _____

Aircraft Registration Number _____

The following action has been taken with respect to this service letter: (Check one)

- Fuselage tube #127 is already properly reinforced.
- Fuselage tube #127 has been properly reinforced per the instructions in this service letter.
- Fuselage tube #127 is not float reinforced, and I do not choose to comply with this service letter at this time.
- I no longer own this airplane. It was sold to:

NAME: _____

ADDRESS: _____

CITY, STATE, ZIP: _____

CERTIFIED BY _____
(Signature)

(Printed Name)

TITLE _____
(Owner, A & P, IA, etc.)

DATE _____

Return this Compliance Record to:

Maule Aircraft Corporation
Spence Air Base
Moultrie, Ga. 31768
Attn: Engineering Manager